

A.S.
 D.S.
 C.E.
 L.I.

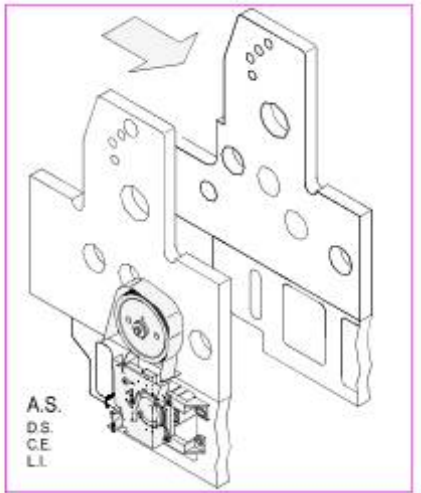

Pos.	Material	Description	Add. description	Assembly	Assembly description	SSU Status	Doc.	Equi	Hints	Note	Rep.
1	G2.004.031 /04	Motorabdeckung		G2.004.030B/	Schutze	H	<input type="checkbox"/>	<input type="checkbox"/>	<input checked="" type="checkbox"/>	<input type="checkbox"/>	<input type="checkbox"/>
2	00.520.0955/	Zylinderschraube	M6x14-Q1	G2.004.030B/	Schutze	A	<input checked="" type="checkbox"/>	<input type="checkbox"/>	<input checked="" type="checkbox"/>	<input type="checkbox"/>	<input type="checkbox"/>
3	42.030.038 /	Scheibe		G2.004.030B/	Schutze	A	<input checked="" type="checkbox"/>	<input type="checkbox"/>	<input checked="" type="checkbox"/>	<input type="checkbox"/>	<input type="checkbox"/>
4	00.520.1830/	Sechskantschraube	M10x 30	G2.004.020B/	Riemenscheibe	A	<input type="checkbox"/>	<input type="checkbox"/>	<input type="checkbox"/>	<input type="checkbox"/>	<input type="checkbox"/>
5	89.090.205 /	Scheibe		G2.004.010B/	Riemenscheibe	A	<input type="checkbox"/>	<input type="checkbox"/>	<input checked="" type="checkbox"/>	<input type="checkbox"/>	<input type="checkbox"/>
6	G2.004.020 /02	Riemenscheibe		G2.004.020B/	Riemenscheibe	A	<input type="checkbox"/>	<input type="checkbox"/>	<input checked="" type="checkbox"/>	<input type="checkbox"/>	<input type="checkbox"/>
7	00.580.3947/	Passscheibe		00.580.3953/	Passscheibe	A	<input type="checkbox"/>	<input type="checkbox"/>	<input checked="" type="checkbox"/>	<input type="checkbox"/>	<input type="checkbox"/>
7	00.580.3948/	Passscheibe		00.580.3953/	Passscheibe	A	<input type="checkbox"/>	<input type="checkbox"/>	<input checked="" type="checkbox"/>	<input type="checkbox"/>	<input type="checkbox"/>
7	00.580.3949/	Passscheibe		00.580.3953/	Passscheibe	A	<input type="checkbox"/>	<input type="checkbox"/>	<input checked="" type="checkbox"/>	<input type="checkbox"/>	<input type="checkbox"/>
7	00.580.3953/	Passscheibe		G2.004.020B/	Riemenscheibe	H	<input type="checkbox"/>	<input type="checkbox"/>	<input type="checkbox"/>	<input type="checkbox"/>	<input type="checkbox"/>
8	00.520.0290/	Zylinderschraube	M12x 35	G2.004.040B/	Motorflansch	A	<input type="checkbox"/>	<input type="checkbox"/>	<input checked="" type="checkbox"/>	<input type="checkbox"/>	<input type="checkbox"/>
9	08.010.026 /	Ring		G2.004.040B/	Motorflansch	A	<input checked="" type="checkbox"/>	<input type="checkbox"/>	<input checked="" type="checkbox"/>	<input type="checkbox"/>	<input type="checkbox"/>
10	00.520.0388/	Sechskantschraube	M10x100	G2.004.040B/	Motorflansch	A	<input type="checkbox"/>	<input type="checkbox"/>	<input checked="" type="checkbox"/>	<input type="checkbox"/>	<input type="checkbox"/>
11	00.520.0415/	Sechskantmutter	M10	G2.004.040B/	Motorflansch	A	<input checked="" type="checkbox"/>	<input type="checkbox"/>	<input checked="" type="checkbox"/>	<input type="checkbox"/>	<input type="checkbox"/>
12	00.520.0254/	Zylinderschraube	M8x25-Q1	G2.004.040B/	Motorflansch	A	<input checked="" type="checkbox"/>	<input type="checkbox"/>	<input checked="" type="checkbox"/>	<input type="checkbox"/>	<input type="checkbox"/>
13	00.580.0028/	Sicherungsscheibe	S 8	G2.004.040B/	Motorflansch	A	<input checked="" type="checkbox"/>	<input type="checkbox"/>	<input checked="" type="checkbox"/>	<input type="checkbox"/>	<input type="checkbox"/>
14	G2.004.040 /04	Motorflansch		G2.004.040B/	Motorflansch	A	<input type="checkbox"/>	<input type="checkbox"/>	<input checked="" type="checkbox"/>	<input type="checkbox"/>	<input type="checkbox"/>
15	00.540.0062/	Zylinderschraube	M6x12-Q1	G2.144.9000/	Elektr. Ausrüstung Zentrale Einricht.	A	<input checked="" type="checkbox"/>	<input type="checkbox"/>	<input checked="" type="checkbox"/>	<input checked="" type="checkbox"/>	<input type="checkbox"/>
16	00.520.0247/	Zylinderschraube	M 6x 45	G2.144.9000/	Elektr. Ausrüstung Zentrale Einricht.	A	<input checked="" type="checkbox"/>	<input type="checkbox"/>	<input checked="" type="checkbox"/>	<input type="checkbox"/>	<input type="checkbox"/>
17	00.520.0630/	Zylinderschraube	M 6x 55	G2.144.9000/	Elektr. Ausrüstung Zentrale Einricht.	A	<input checked="" type="checkbox"/>	<input type="checkbox"/>	<input checked="" type="checkbox"/>	<input type="checkbox"/>	<input type="checkbox"/>
18	00.520.0427/	Sechskantmutter	BM12	G2.004.040B/	Motorflansch	A	<input checked="" type="checkbox"/>	<input type="checkbox"/>	<input checked="" type="checkbox"/>	<input type="checkbox"/>	<input type="checkbox"/>

Pos.	Material	Description	Add. description	Assembly	Assembly description	SSU Status	Doc.	Equi	Hints	Note	Rep.
1YB3.1	G2.101.1021/	Bremsscheibe		G2.144.9000/	Elektr. Ausrüstung Zentrale Einricht.	A	<input type="checkbox"/>	<input type="checkbox"/>	<input checked="" type="checkbox"/>	<input checked="" type="checkbox"/>	<input type="checkbox"/>
1YB3.2	G2.101.1031/01	Bremsbelag		G2.144.9000/	Elektr. Ausrüstung Zentrale Einricht.	A	<input type="checkbox"/>	<input type="checkbox"/>	<input checked="" type="checkbox"/>	<input checked="" type="checkbox"/>	<input type="checkbox"/>
1YB3.3	G2.101.1011/02	Bremszylinder		G2.144.9000/	Elektr. Ausrüstung Zentrale Einricht.	A	<input type="checkbox"/>	<input type="checkbox"/>	<input checked="" type="checkbox"/>	<input type="checkbox"/>	<input type="checkbox"/>
M1	G2.101.2003/	Hauptmotor		G2.144.9000/	Elektr. Ausrüstung Zentrale Einricht.	H	<input checked="" type="checkbox"/>	<input type="checkbox"/>	<input checked="" type="checkbox"/>	<input type="checkbox"/>	<input type="checkbox"/>
M1	G2.101.2003/02	Hauptmotor		G2.144.9000/	Elektr. Ausrüstung Zentrale Einricht.	H	<input checked="" type="checkbox"/>	<input type="checkbox"/>	<input checked="" type="checkbox"/>	<input checked="" type="checkbox"/>	<input checked="" type="checkbox"/>